



be in motion

Universal prober manipulator



# neptune compact

- Max. test head weight up to 650 kg / 1430 lbs
- Universal "hinge" manipulator for different 200 / 300 mm probes
- Linear vertical motion for linear docking
- Tactile test head mounting for stress-free docking
- Fully motorized



esmo AG phone +49-8031-233 88 0  
 Brückenstrasse 1 fax +49-8031-233 88 10  
 D-83022 Rosenheim sales@esmo-ag.com  
 Germany www.esmo-ag.com

esmo asia north co., ltd. phone +86-216240-0990  
 No. 1118, Changshou Road fax +86-216240-0990  
 Yueda International Plaza, Tower B, Unit 9-D sales@esmo-ag.com.cn  
 200040 Shanghai, China www.esmo-ag.com

esmo asia south pte. ltd. phone +65-6562-8833  
 25 International Business Park fax +65-6562-8860  
 #03-112 German Centre sales@esmo-asia.com  
 Singapore 609916 www.esmo-ag.com

esmo usa inc. phone +1-408-982 9911  
 3350 Scott Blvd., Suite #6102 fax +1-408-982 9933  
 Santa Clara, CA 95054 sales@esmo-usa.com  
 USA www.esmo-ag.com

## neptune compact

Universal prober manipulator

### Key Features

Compactness: Low manipulator weight with high load capacity  
 Universality: Docking with different test heads and probers  
 Modularity: Easily removable footing for shipping  
 Tactility: No merchandising interfacing hardware required for test head docking  
 Convenience: Process control incl. vertical movement: Only 2 control buttons ("dock"/"undock")  
 Cable management: Active movement  
 Reliability: Deactivation of force in the event of resistance  
 Maintenance-free

### Specifications

#### Weight

Max. test head weight 650 kg/1430 lbs  
 System weight Empty: 730 kg/1606 lbs FPully loaded: 1380 kg/3063 lbs

#### Linear

Vertical travel (z-axis) 200 mm  
 Rotation 180°

#### Test Head Mounting

Tumble ± 3°;  
 Twist ± 2°  
 Theta adjustment ± 2°

#### Motorized

- 
- 

#### Tactile

- 
- 
- 

### Typical Tester Configurations

Advantest: T2000, T5771, T5375, T66xx, etc.  
 Credence: Sapphire, Kalos  
 Eagle Test Systems: ETS600  
 LTX: Fusion HF, HFi  
 Teradyne: J750, Catalyst, Micro-FLEX, FLEX, Ultra-FLEX  
 Verigy: V93000 soc. V4500, etc.

### Power Requirements

Three-phase power supply  
 Range of 80 to 480 volt  
 Max. 16 amp

### Dimensions

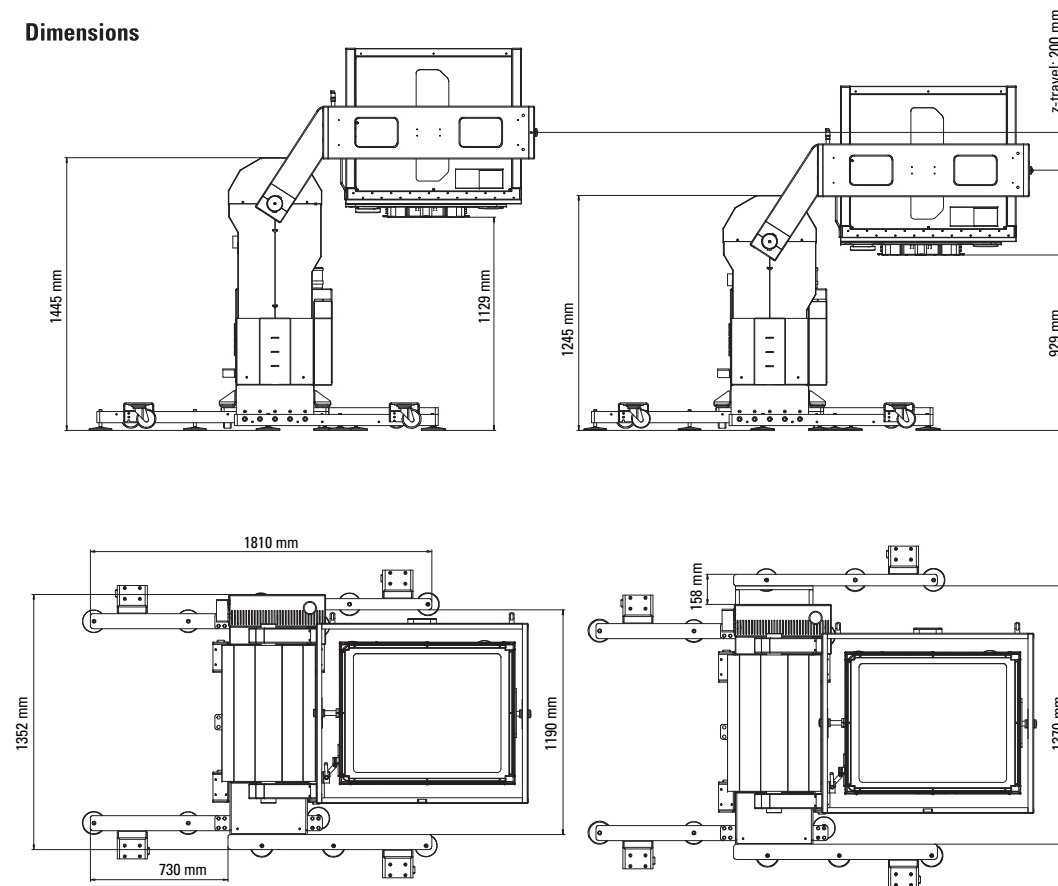

Subject to technical change  
 without prior notice  
 © 2008



Test head service position



Lift test head 150 mm



Rotate test head 180°



Lower test head 150 mm



Test head in docked position